

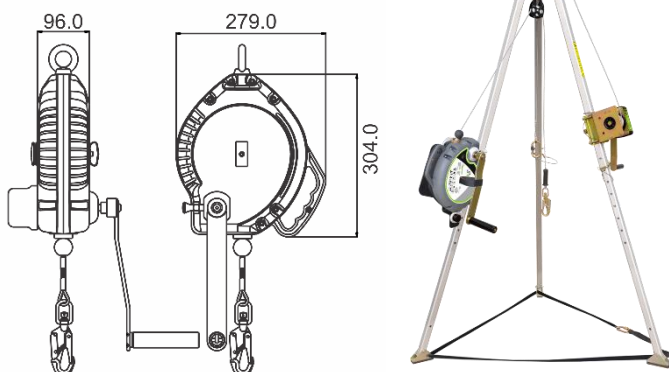

TECHNICAL SHEET FA 20 401 20

OLYMPE CABLE, 20 MTRS RETRACTABLE FALL ARRESTER WITH INTEGRATED RESCUE WINCH

Olympe



Length:	CE	Weight:
20 m		9,20 kg

KRATOS SAFETY

ZI les Portes du Dauphiné
4, rue de l'Aigue
69780 Saint Pierre de Chandieu – FRANCE

Tel. : +33 (0)4 72 48 78 27

Fax. : +33 (0)4 72 48 58 32

www.kratossafety.com / info@kratossafety.com

- Casing made up of high impact strength Polymer, to prevent breakage.
- Comes with Galvanized steel wire rope of diam. 4.5 mm.
- Internal braking mechanism to reduce the fall arrest force to less than 6 kN.
- Swivel and steel screw-locking karabiner FA 50 101 17, opening 18 mm, at anchorage end, and steel snap hook FA 50 203 20, opening 20 mm, with swivel and load indicator at attachment end.
- Integrated recovery system.
- The device can be adapted on our TRIPOD (FA 60 001 00 or FA 60 002 00) through the Kit FA 60 001 03, as well as on MultiSafeWay (FA 60 022 00) through the plate FA 60 022 04.
- **Minimum breaking strength > 12 kN.**

Compliance: Conforms with EN360:2002 and EN1496:2006 Class B.

Material of components:

Protecting casing: PA 6 30% fiberglass.

Wire rope: Galvanized Steel.

Connectors: Steel.

HS CODE
84289090
CARTON SIZE / PIECES
59 X 38 X 28 cm / 1
AET N° I E
Satra Technology Centre, N°0321 Wyndham Way, Telford Way, Kettering Northamptonshire, NN16 8SD, United Kingdom
ARTICLE 11 GB07/73551
SGS United Kingdom Ltd., N°0120 Unit 202B, Worle Parkway, Weston-super-Mare, BS22 6WA, United Kingdom